

WARRANTY

HAULOTTE
5 YEARS



COMPACT 10 COMPACT 12 COMPACT 14 DUAL



SMART RUGGED DESIGN

- > Impact-proof counterweight with integrated ladder protection, AC motors and charger plug
- > Reinforced guardrails with additional vertical stiles for maximum durability

MAXIMIZED POTENTIAL

- > Access all worksites: foldable guardrails, lateral & longitudinal forklift pockets
- > IN/OUT usage with no platform weight capacity restriction

UNIQUE USER EXPERIENCE

- > Proportional movements for precise driving (AC motors)
- > Ergonomic upper control box with grab handle & speed selector

UNBEATABLE SERVICEABILITY

- > Haulotte Activ'Energy Management for battery care
- > On-board & remote settings and diagnostic tools with Haulotte Diag, Haulotte Activ'Screen and Sherpal telematics solution

COMPACT 10 COMPACT 12 COMPACT 14 DUAL

ELECTRIC SCISSOR LIFTS

TECHNICAL DATA

	COMPACT 10 AE	COMPACT 12 AE	COMPACT 14 DUAL
Working height - indoor	10 m	11.75 m	13.75 m
Working height - outdoor	10 m	11.75	9.8 m
Platform height - indoor	8 m	9.75 m	11.75 m
Platform height - outdoor	8 m	9.75	7.8 m
Max. drive working height - indoor	10 m	11.75	11.75 m
Max. drive working height - outdoor	10 m	11.75 m	9.8 m
Lift capacity - inside	450 kg (3 pers.)	320 kg (3 pers.)	
Lift capacity - outside	450 kg (1 pers.)	320 kg (1 pers.)	
Lift capacity on the extension	120 kg		
A Platform length	2.4 m		
B Platform length - extended	3.32 m		
Length - extension	0.92 m		
C Platform width - outside	1.17 m		
D Height - stowed	2.35 m	2.47 m	2.72 m
Height - guardrails lowered	1.65 m	1.77 m	2.02 m
E Overall width	1.20 m		
F Length	2.5 m		
G Wheelbase	1.86 m		
H Ground clearance - center	12.5 cm		
Ground clearance - deployed potholes	2 cm		
Low drivespeed	0.7 / 1.5 / 4.2 km/h		
Gradeability	25 %		
Tilt (longitudinal / lateral)	3.5° / 1.5°		
Turning radius - outside	1.83 m		
Non-marking tyres	15 x 5		
Batteries	24 V - 225 Ah (C20)		
Hydraulic system capacity	10 l	14 l	
Weight	2 490 kg	2 940 kg	3 070 kg

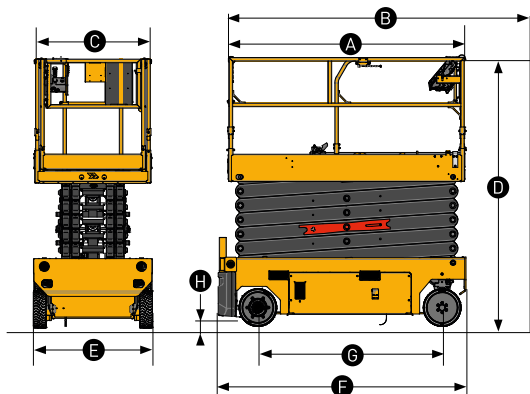

STANDARD EQUIPEMENT

- > Haulotte Activ'Screen: on-board diagnostic and setting screen
- > Haulotte Activ'Energy Management: Smart CAN charger with manual battery water filling system
- > Versatile use : outdoor/ indoor
- > Foldable guardrails
- > Front platform extension
- > Drop bar
- > AC motors
- > 27A multivoltage charger
- > Mobile pothole guards
- > Battery access with swing out tray
- > Lateral & longitudinal forklift pockets
- > Motion alarm
- > Single flashing light
- > 2 front steering wheels, 2 rear drive wheels
- > Solid non marking tires

OPTIONS & ACCESSORIES

- > Haulotte Activ'Energy Management: automatic battery water filling systems
- > Secondary guarding system
- > Telematics solutions
- > AGM maintenance-free batteries
- > Pipe cradle
- > Panel carrier
- > Additional protection of upper & lower control box
- > Working light
- > Flashing light (dual or 360°)
- > Biodegradable hydraulic oil
- > Cold weather hydraulic oil

